

Labmate



Vertical Autoclave

LMVT-A303

info@labmate.com | www.labmate.com

Index

Sr.no	Title	Page no
1.	Safety Measures	2
2.	Introduction	3
3.	Features	3
4.	Specifications	4
5.	Applications	4
6.	Instrument Introduction	5
7.	Operations	7
8.	Circuit Diagram	9

1. Safety Measures

- The operator of the sterilizer should possess the necessary operational knowledge and take responsibility for regular maintenance to prevent accidents.
- Ensure there is sufficient water in the unit (approximately 20 liters) and keep the water level at the indicated mark. However, avoid overfilling, as excessive water can prolong the drying time for surgical dressings.
- At the beginning of heating, the releasing valve must be set to the “releasing” position to expel cool air from the pail.
- Do not sterilize different types of items simultaneously, such as surgical dressings with solutions or rubber goods with instruments, as this may compromise the effectiveness of the sterilization process.
- Solutions to be sterilized should be placed in heat-resistant flasks, filled to no more than 1/2 to 3/4 of their capacity. Flasks should be covered with absorbent gauze, not non-porous plugs like rubber or cork stoppers. Place the flasks on a tray within the container to catch any potential spills and prevent contamination of other items.
- After each sterilization cycle, drain the water from the sterilizer by opening the draining valve located at the bottom right of the unit. Dry the sterilizer and clean any water stains to enhance sterilization quality and extend the equipment's lifespan.
- Use a recording thermometer, sterilization indicator, or other biological methods to verify that the required temperature and time are achieved for reliable sterilization.
- If the pressure gauge becomes inaccurate or the needle does not return to the “zero” position after extended use, replace it with a new one.
- Replace the gasket on the lid if it becomes hardened from prolonged use.
- Once the pressure-temperature selection knob is set to a specific value, it generally does not require re-adjustment. However, regularly check to ensure the setting remains accurate.
- To release steam, open the safety valve and lower the spanner. If significant steam leakage occurs, move the spanner up and down several times to stop the leakage.

2. Introduction

Vertical Autoclave LMVT-A303 is a top-loading, compact autoclave that offers exceptional stability for quick and precise drying or sterilizing. Designed with an automatic outflow of cool air and steam for ease of use. Equipped with a simple-to-read LED display that makes it possible to clearly see intuitive functioning. Constructed with a durable stainless steel chamber that holds a capacity of 100 L for safe and convenient operation.

3. Features

- Enhanced with quick and simple operation, all parameters are shown on an LED panel
- Constructed with scratch-free stainless steel ensures a long working life
- Energy-efficient microprocessor control system simple to use with push control button
- Tool-free cleaning with cost-effective maintenance
- Effortless handling with safety and sanitation
- Integrated with an alarm system that triggers indication during automatic shut-off
- Equipped with a safety control system to prevent protection against over-temperature and over-heating
- Easily operated with high reliability and durability

4. Specifications

Model No.	LMVT-A303
Capacity	100 L
Working Pressure	0.22 MPa
Maximum Pressure	0.23 MPa
Temperature Range	134 °C
Sterilizing Temperature	0 - 134 °C
Heat Average	$\leq \pm 1$ °C
Time Range	0 - 99 min or 0 - 99 hours 59 min
Material	Stainless steel
Power	4.5 kW
Voltage	220 V
Chamber Size	φ 400 × 650 mm
Dimension	730 × 510 × 1270 mm
Net Weight	110 Kg
Gross Weight	135 Kg

5. Applications

It is extensively used to sterilize surgical equipment, laboratory instruments, pharmaceutical items, and other materials.

6. Instrument Introduction

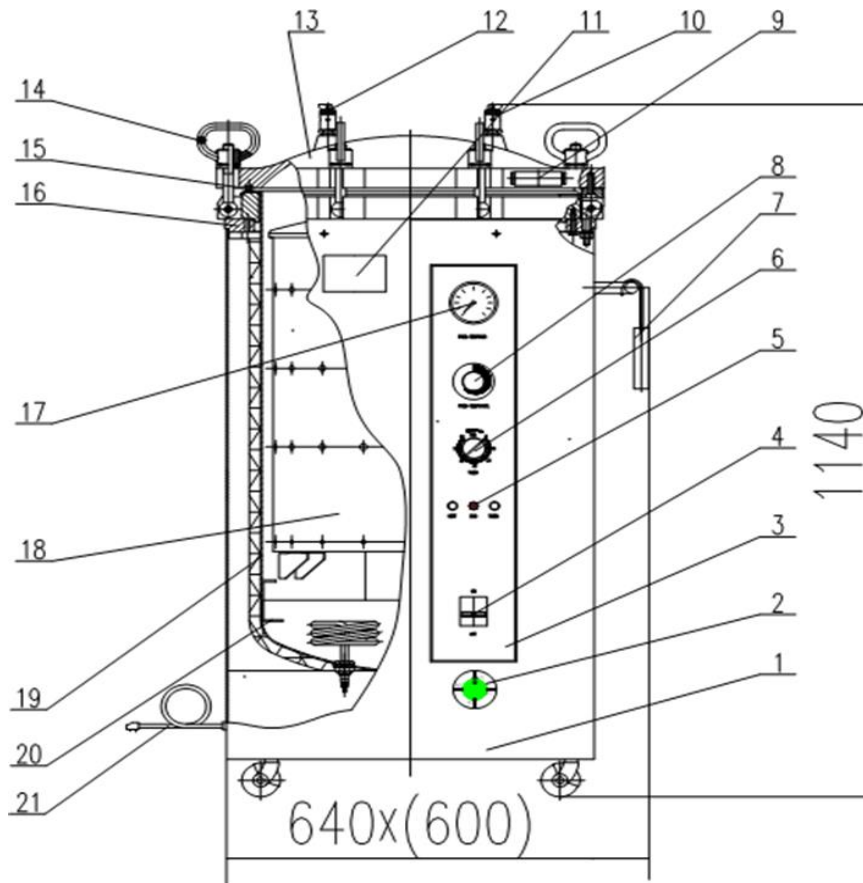

Figure-1

- | | |
|--|------------------------|
| 1) Housing | 15) Gasket |
| 2) Drainage knob | 16) Flange |
| 3) Control board | 17) Pressure gauge |
| 4) Overload power switch | 18) Sterilization pail |
| 5) Pilot | 19) Container |
| 6) Timer | 20) Water level |
| 7) Spanner | 21) Power cable |
| 8) Pressure-temperature selection knob | |
| 9) Handle | |
| 10) Safe valve | |
| 11) Brand | |
| 12) Safe valve | |
| 13) The lid of the container | |
| 14) Tightening bolt | |

Vertical Autoclave LMVT-A303

- 1) **Unit Structure:** The unit features a single-layer cylindrical body, designed, manufactured, and inspected in strict accordance with the Standards of Utilization Safety for Pressure Vessels.
- 2) **Material:** The main body is constructed from high-quality stainless steel, offering resistance to corrosion, ease of maintenance, and a long service life.
- 3) **Design:** The unit has a quadrate outline. The display and control switches are centrally located on the front controller board, providing convenient access.
- 4) **Steam Pressure Stabilizer:** Equipped with a steam pressure stabilizer with a range of 0.04 – 0.22 MPa (equivalent to a steam temperature range of 109 – 134°C), the unit can effectively sterilize various objects.
- 5) **Timer Function:** The unit includes a timer that activates when the temperature reaches the preset level. The timer indicator light will turn on, and the timer will start automatically. Upon completion of the sterilization cycle, the power will be disconnected, and an alarm will sound.
- 6) **Heating Elements:** The unit uses immersion tubes (4.5 kW/220 V) for heating, ensuring high efficiency. The unit must be grounded properly.
- 7) **Safety Valve:** A spring safety valve with a rated pressure of 0.165 MPa is used. During normal operation, the valve remains closed. It will automatically open to release steam if the pressure exceeds the working limit and will close once the pressure returns to normal, ensuring safe operation.
- 8) **Overload and Leakage Protection:** An overload and leakage protector (OLP) are incorporated to automatically disconnect the power in case of over-voltage or leakage, enhancing safety.

7. Operations

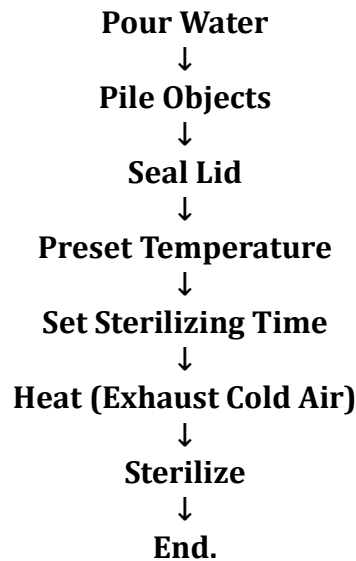

- 1) **Add Water:** Open the cover and remove the sterilization pail. Pour approximately 20 liters of clear, soft water into the water to reach the marked line. Be careful not to overfill. During sterilization, the water will gradually decrease as it vaporizes. If re-sterilization is required, refill the unit with water.
- 2) **Pile Object:** Bind the objects to be sterilized and arrange them in order on the sieve board inside the pail. Ensure there is an appropriate gap between each package. Typically, the volume of each package should not exceed 200 x 200 x 100 mm.
- 3) **Seal Lid:** Place the pail into the unit, close the cover, and then evenly tighten the bolts to seal the cover. Be careful not to overtighten to avoid damaging the rubber gasket.

Preset Sterilizing Time: The user can preset the desired sterilizing time (refer to **Table 1**) using the table below. Turn the timer knob clockwise to the desired time setting. Once the unit reaches the preset temperature, the time indicator light will turn on, and the timer will automatically start counting.

Reference table to sterilization time and temperature (Table 1)

Table-1

Objects	Required heat preservation time (min)	Steam Pressure Mpa	Relative steam Temperature °C
Rubber goods	15	0.1 - 0.11	121
Surgical dressings	15 - 20	0.1 - 0.22	121- 134
Utensils	8	0.1 - 0.22	121- 134
Instruments	10	0.1 - 0.22	121- 134
Solution in flasks	20 - 40	0.1 - 0.145	121- 126

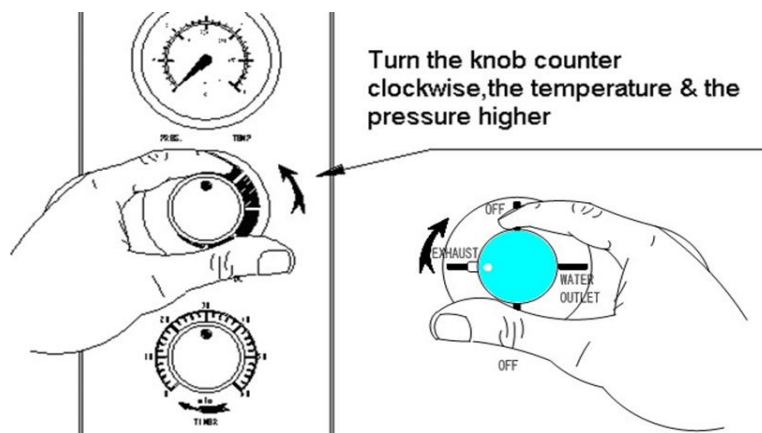

Figure-2

Preset sterilizing temperature: The preset sterilizing temperature is controlled by a pressure-temperature controller with a range of 109°C to 134°C. Turning the knob clockwise decreases the preset temperature while turning it counterclockwise increases it. The maximum temperature setting is 134°C, and the machine is factory-adjusted to this maximum value (with the safety valve set to open). Users can adjust the sterilizing temperature according to their needs (refer to **Figure 2**).

Heat (Exhaust cold air): Ensure that power is connected, and the overload protector is activated. Next, set the "Source Power" switch to the "On" position. The power pilot light should illuminate, and the control circuit will enter the working state, indicated by the "Heating" pilot light. Turn the release valve knob to the release position (refer to **Figure 2**). When a small amount of steam is released (pressure is 0 MPa), turn off the release valve knob. This step will expel any residual cool air from the container, thereby enhancing the sterilizing effect.

Sterilize: When the pressure and temperature in the pail reach the preset values, the heating indicator will turn off. At this point, the pressure gauge should display the preset value. If the value is insufficient, adjust the pressure-temperature controller counterclockwise. This will increase the temperature, and the heating pilot light will re-illuminate until the temperature reaches your desired value. Once the target temperature is achieved, the machine will automatically enter a constant temperature control mode within the timer's range. The timer will start counting automatically. When the preset time is reached, the main circuit will be cut off, a buzzer will sound, and the sterilization process will end.

End: Turn off the power switch. For surgical dressings and utensil instruments, release the steam in the sterilizer through the releasing valve (or simultaneously open the safety valve). When the pressure gauge reads "Zero," wait one minute before opening the cover and removing the sterilization pail. For solutions, culture media, or similar items, avoid opening the releasing valve immediately after sterilization. Doing so could cause the solution to boil violently, potentially breaking the bottles and causing leaks due to the sudden pressure drop. Instead, wait 20 to 30 minutes until the pressure in the vessel drops to "Zero." Then, open the releasing valve and the cover before removing the pail.

8. Circuit Diagram

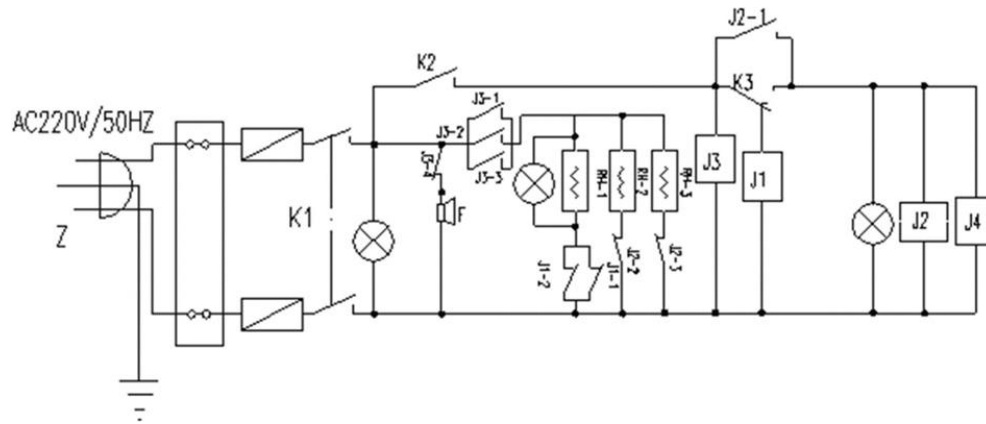

Labmate Scientific Inc 444 W Lake Street Chicago IL 60606 USA
Email: info@labmate.com | Website: www.labmate.com